



Area of application: basic principles

## **The maintenance switch (safety switch)**

### **Protective device against unexpected start-up**

Suva  
Swiss National Accident Insurance Fund  
Section Technology  
Accredited Certification Body SCESp 0008  
European notified body, identification number 1246  
Rösslimattstrasse 39  
6005 Lucerne  
Switzerland

Phone +41 (0) 58 411 12 12  
<http://www.suva.ch/certification-e>

**The maintenance switch  
(safety switch)**

**Protective device against unexpected start-up**

Author : Urs Bühlmann, Giuseppe Carlantuono,  
Mathias Hartmann, Marcel Reiter,  
Daniel Vock  
Issued : 01.01.2022  
Order no. : **CE93-9.e (Available only as a pdf file)**

**Summary**

During work such as maintenance, repair, cleaning or troubleshooting, accidents occur time and again because machines start moving unintentionally due to technical faults or human error, or because stored energy is suddenly released. The maintenance switch is a tried and tested means of preventing such accidents.

This publication contains information about the necessity of maintenance switches in machinery and plants and about the requirements of maintenance switches. It also provides instructions on how to use them correctly.

---

## Contents

1	Introduction.....	5
1.1	Changes compared to the previous versions .....	5
1.2	General .....	5
1.3	Laws, guidelines and standards.....	6
1.4	Machine or installation?.....	6
1.5	Functional units .....	6
2	Procedure .....	8
2.1	Is a maintenance switch necessary? .....	8
2.2	Are mechanical hazards present? .....	9
2.3	Is access needed to the hazard zone?.....	10
2.4	Does the main switch need to remain switched on?.....	10
2.5	Is the main switch easily accessible?.....	10
3	Requirements .....	12
3.1	Requirements of the equipment.....	12
3.2	Requirements of the function .....	13
3.3	Requirements for positioning.....	14
3.4	Indirect shutdown .....	14
4	Formation of functional units.....	16
5	Main switch as maintenance switch .....	17
6	Instructions for users.....	17
7	Schematic diagrams.....	18
7.1	Direct shutdown, Example 1 .....	18
7.2	Direct shutdown, Example 2 .....	19
7.3	Indirect shutdown, Example 3.....	20
7.4	Indirect shutdown, Example 4.....	21
7.5	Division of a system into functional units, Example 5.....	22

## 1 Introduction

### 1.1 Changes compared to the previous versions

The structure of this publication has been completely revised compared to the previous versions. After the introduction, the first issue to be addressed is whether a maintenance switch is needed at all. The requirements are explained in the subsequent sections.

The references to the underlying European standards have been updated.

As part of the revision dated 01.01.2022, the requirements for plug/socket combinations have been integrated in Section 3.1 and the requirements for indirect shutdown have been adjusted in Section 3.4.

### 1.2 General

In order for a machine to be placed on the market in the European Union, the European Economic Area and Switzerland (and other countries), the essential health and safety requirements of Annex I of the Machinery Directive 2006/42/EC must be fulfilled. These legally binding requirements stipulate that the manufacturer must prepare a risk assessment and carry out a risk reduction process for the machine being built.

One possible solution for reducing the risk of mechanical hazards is the use of the maintenance switch, which serves to safely shut down and disconnect the energy supply and prevent the unexpected start-up of one or more sections of a technical device. This makes it possible to work safely during e.g. maintenance, repair, cleaning or troubleshooting without putting the entire system out of operation.

The maintenance switch is a complementary protective measure<sup>1</sup>, not a safeguarding measure (such as e.g. interlocking guards, light curtains, etc.). This means that it cannot be used as a replacement for safeguarding measures and human intervention is always necessary.

The maintenance switch is not intended to shut down a system, but to prevent it restarting unexpectedly.

This document gives explanations on direct shutdown with electrical disconnection, as described in EN 60204-1:2018, para. 5.4.

Section 3.4 of this document describes indirect shutdown, which is not covered in EN 60204-1:2018. In Switzerland, this is considered a tolerated deviation from the standardised solutions and must therefore be limited to exceptions.

The maintenance switch is also called a safety switch, repair switch, etc. In this document, only the term maintenance switch is used. It must be expected that other documents and publications will continue to use the term safety switch for some time to come. It is therefore advisable to clarify exactly what is meant.

Requirements for the maintenance switch can be found in various documents. These requirements are summarised in this publication.

---

<sup>1</sup> EN ISO 12100:2010, 6.3.5

### 1.3 Laws, guidelines and standards

The basics on the subject are outlined in the following laws, guidelines and standards:

- Directive 2006/42/EC (Machinery Directive), Appendix I, Section 1.6.3;
- EN ISO 12100:2010, Safety of machinery - General principles for design - Risk assessment and risk reduction, Sections 6.3.2.4 and 6.3.5.4;
- EN 60204-1:2018, Safety of machinery - Electrical equipment of machines. Part 1: General requirements, Section 5.4;
- EN ISO 14118:2018, Safety of machinery - Prevention of unexpected start-up;
- APO (Ordinance on the Prevention of Accidents and Occupational Diseases, SR 832.30), Art. 30;
- Swiss standard SN 411000:2020, Low-voltage installation standard (NIN 2020), Sections 4.6.4 and 5.3.7.3.2.

Requirements for enclosures and their labelling can be found in:

- EN 62626-1:2014, Low-voltage switchgear and controlgear enclosed equipment - Part 1: Enclosed switch-disconnectors outside the scope of IEC 60947-3 to provide isolation during repair and maintenance work

NOTE: A European standard (EN) must be obtained as a national standard from the national standards organisation (Swiss Association for Standardisation (SNV) or Electrosuisse). The content is identical, but the year may be different (e.g. EN 60204-1:2018 is available as SN EN 60204 1:2019).

### 1.4 Machine or installation?

For machines as defined by the Machinery Directive, the requirements for the electrical equipment, i.e. including the maintenance switch, are specified by EN 60204-1:2018.

If work equipment does not fall within the scope of the Machinery Directive, reference can be made to the low-voltage installation standard SN 411000 (NIN), para. 4.6.4 "Schalten für Wartungsarbeiten" (Switching for maintenance work).

If cables to and from the maintenance switch are permanently connected to the building, e.g. in a cable tray, these cables are also considered part of the installation according to the Ordinance on Low-Voltage Installations, NIV (communication from the Federal Inspectorate for Heavy Current Installations ESTI in Bulletin 9/2014). A corresponding permit is required for the construction of this part of the installation.

### 1.5 Functional units

A system or large machine must already be divided into appropriate functional units at the planning stage, and a maintenance switch must be assigned to each unit. The aim is to ensure that the operational and safety requirements for the machine are met.

Such functional units can be shut down individually for work such as maintenance, repair, cleaning or troubleshooting, while the other functional units of the machine can continue to operate safely.

The functional units of the system or machine are to be determined as part of the risk assessment and risk reduction process.

Further information on this subject can be found in Section 4 “Formation of functional units”.

## 2 Procedure

### 2.1 Is a maintenance switch necessary?

The following flow chart must be used to decide whether maintenance switches are required.

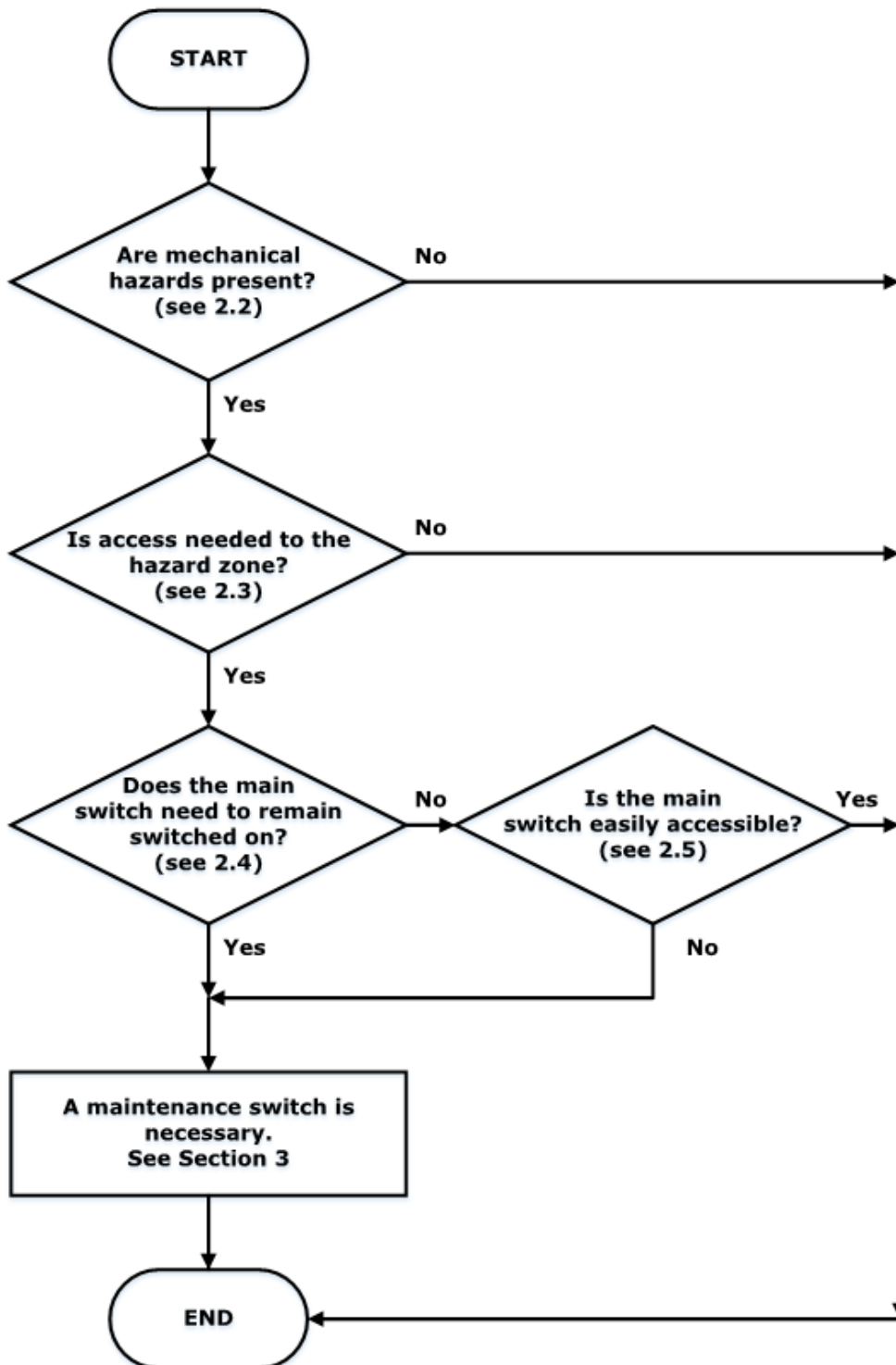



## 2.2 Are mechanical hazards present?

The hazards and associated hazardous situations must be identified as part of the risk assessment.

A hazard due to an unforeseen start-up can be caused by one of the following, for example:

- a start command generated by an error in the control system (failure of a component/software error);
- a start command generated by an external influence on the control system (electromagnetic field);
- a start command generated by incorrect operation of manual controls (actuators) (accidental actuation of the start button);
- a start command generated by activation of a sensor or a power control element (accidental interruption of a light beam device, manual actuation of a contactor);
- restoration of energy supply after an interruption;
- external or internal influences on parts of the machine (gravity, wind, self-ignition in combustion engines, etc.)

The risk assessment shall consider all forms of energy that can cause mechanical hazards, in particular electrical, pneumatic, hydraulic and potential energy.

Such hazards can include the following:

- mechanical hazards due to someone reaching into unprotected moving or rotating parts (crushing, shearing, pinching, impact, severing, stabbing, drawing in, trapping, entanglement, winding, cutting, friction or abrasion);
- mechanical hazards due to parts, material or substances that are moved by a machine, stored energies, falling objects;
- mechanical hazards due to moving means of transport, moving work equipment (collision or impact, being run over, overturning in means of transport, falling, being thrown, approach of a moving part to a fixed part);
- mechanical hazards due to uncontrolled moving parts (tipping over and colliding with the person or objects, rolling over, knocking over, falling down, parts flying away and colliding with the person or object);
- hazards from pressurised media.

The maintenance switch is a protective device against unexpected start-up within the meaning of EN 60204-1:2018, para. 5.4. It primarily protects against mechanical hazards by disconnecting the drive from the energy source. Parts of the electrical equipment may still be live, for example overtemperature switches on the motor or heaters. For protective devices against electrical hazards, see EN 60204-1:2018, para. 5.5.

### **2.3 Is access needed to the hazard zone?**

If access to the hazard zone is required for work such as maintenance, repair, cleaning or troubleshooting, the functional unit must be shut down and restarting prevented. Safeguarding measures such as interlocking (monitored) devices are not sufficient for this; complementary protective measures such as maintenance switches are needed to disconnect the energy supply.

**EXAMPLE 1:** Sometimes the removal of a fixed guard is necessary to access the hazard zone. Moving parts in the hazard zone must be disconnected from the energy source for as long as the guard is not in the protective position.

**EXAMPLE 2:** Areas where robots or other automated machines are working can, for example, be equipped with light curtains that stop any machine movement as soon as a person enters the hazard zone during the production process. However, longer interventions such as weekly cleaning require the moving parts to be disconnected from the energy source.

**EXAMPLE 3:** If parts of the cover of a conveyor belt have to be dismantled for cleaning work or if the hazard zone has to be entered, then the drive must be disconnected from the energy source.

### **2.4 Does the main switch need to remain switched on?**

If certain parts of the machine or system continue to operate while other functional units need to be disconnected from the energy source for maintenance, repair, cleaning or troubleshooting, the main switch can remain switched on provided these functional units are equipped with a maintenance switch and are disconnected.

**EXAMPLE 1:** At a plant with several production lines, a malfunction has to be repaired on one line while the other lines can continue to operate.

**EXAMPLE 2:** If control system function is required for maintenance, repair, cleaning or troubleshooting, the main switch must remain switched on.

**EXAMPLE 3:** A machine control sensor has to be replaced in the hazard zone of infeed points. The energy supply is needed for the adjustment, but the hazardous movements at the infeed points must be stopped and disconnected from the power.

**EXAMPLE 4:** The maintenance staff are exposed to an unexpected start-up of machine parts while troubleshooting the control logic (with the main switch on). For troubleshooting of the control system, the main switch must remain switched on, but the hazardous movements must be stopped and disconnected from the power.

### **2.5 Is the main switch easily accessible?**

The main switch is considered to be easily accessible if it is located in the immediate vicinity of the point of intervention or in a place that must be passed when accessing the point of intervention.

If the main switch is not easily accessible, there is a risk that the machine may be worked on without the main switch being switched off. A maintenance switch is required in this case.

The main switch must be externally operable and positioned between 0.6 m and 1.9 m above the access level. An upper height limit of 1.7 m is recommended.<sup>2</sup>

EXAMPLE 1: Small machine (e.g. planing machine)

→ In general, a maintenance switch is not required.

EXAMPLE 2: HVAC system with fan (heat exchanger) on roof and main switch on the central control panel

→ As the main switch is not easily accessible, a maintenance switch must be installed at the fan.

---

<sup>2</sup> EN 60204-1:2018, 5.3.4

### 3 Requirements

#### 3.1 Requirements of the equipment

The maintenance switch must

- ensure all-pole disconnection<sup>3</sup>  
(Disconnect – or disconnect function – means that the unit has a sufficient separation distance between the opened contacts and a reliable mechanical connection between the manual control (actuator) and the contact elements);
- have clear labelling of the ON and OFF position<sup>4</sup>;
- be labelled with the text “Maintenance switch”<sup>5</sup>;
- make it easy to identify which machine or machine parts it disconnects<sup>6</sup>, e.g. by means of a pictogram or by labelling such as “Maintenance switch for extraction fan 1”;
- have a reliable mechanical connection between the manual control (actuator) and the element(s) to be disconnected<sup>7</sup>;
- have two switch settings (usually), e.g. 0 (OFF) and I (ON)<sup>8</sup>;
- be able to be secured in the OFF position against unauthorised and unintentional restarting by means of several personal padlocks (at least 3 are recommended)<sup>9</sup>;

NOTE: If more padlocks are required than the maintenance switch can accommodate, multiple locking bars must be used.



Figure 1: Maintenance switch with multiple locking bar

- be black or grey (exception: if the maintenance switch is also used as an emergency stop switch, it must have a red handle and a yellow background).

<sup>3</sup> EN ISO 14118:2018, 5.2.1

<sup>4</sup> EN 62626-1:2014, 6.2.1 a)

<sup>5</sup> EN 62626-1:2014, 6.2.1 c)

<sup>6</sup> EN ISO 14118:2018, 5.2.2

<sup>7</sup> EN ISO 14118:2018, 5.2.1

<sup>8</sup> EN 60204-1:2018, 5.3.3

<sup>9</sup> EN 62626-1:2014, 9.2

This is only possible for the main switch that also performs the function of the maintenance switch and meets the requirements of standard EN 60204-1:2018, para 10.7.3)<sup>10</sup>;

- be designed in such a way that restarting in the locked OFF state is prevented (this must be taken into account especially when setting up the maintenance switch with disconnectable switching unit, see also remark in Section 5).

NOTE: If the rated current does not exceed 16 A, a plug/socket combination can also be approved instead of a maintenance switch. Taking into account the requirements for plug/socket combination according to EN 60204-1:2018 para. 5.3.3, devices with rated current > 16 A can also be used. The following requirements, among others, must also be observed:

- Rated current > 16 A, mechanical locking device is provided to prevent unintentional or accidental disconnection.
- Rated current  $\geq$  30 A, additional controlgear is required, disconnection or connection only possible when controlgear is in OFF position.

Lockable devices shall be used to prevent re-insertion of the plug. The lockable device may be dispensed with if the separate plug/socket combination is at all times under the control of the person carrying out the intervention on the machine.

### 3.2 Requirements of the function

- The maintenance switch must have priority over the power-on devices in all operating modes.
- The maintenance switch must disconnect the supply of all hazardous energies to the system.
- The maintenance switch must reduce (e.g. vent pneumatics) or safely retain the hazardous energies stored in the system<sup>11</sup>.
- Where the reactivation of the maintenance switch can lead to a hazardous situation, e.g. when the power supply is restored after an interruption or when the machine starts automatically, unexpected start-up must be prevented. Switching off the maintenance switch must therefore reset the control commands stored by the control system.
- Where the maintenance switch also has the “emergency stop” function, its reactivation must not trigger an unexpected start-up. Switching off the maintenance switch must therefore reset the control commands stored by the control system.

---

<sup>10</sup> EN 60204-1:2018, 5.3.4

<sup>11</sup> EN ISO 14118:2018, 5.4

### 3.3 Requirements for positioning

The maintenance switch must

- be safely and easily accessible;
- be able to be operated without having to open an electrical cabinet (unless used exclusively by expert or trained individuals<sup>12</sup>);
- always be arranged in such a way that the part of the system that is switched off can be seen;
- always be positioned in the immediate vicinity of the intervention site (i.e. on site) or at a location that must be passed when accessing the intervention site;
- be installed at multiple locations, namely wherever there are interventions in the system, in the case of large-scale systems or systems that are distributed over several rooms.

Sometimes the requirements for the switch to be “on site” and “easily accessible” are contradictory. In case of doubt, the “easily accessible” requirement is to be given priority.

EXAMPLE 1: 20 m long conveyor belt at a height of 5 m without direct access from the floor.

→ The maintenance switch must be accessible from the floor because the place of intervention is not necessarily at the drive.

EXAMPLE 2: Single unit (e.g. fan) at a height of 5 m without direct access from the floor.

→ Maintenance switch next to the fan, because the fan needs to be accessed anyway during an intervention.

EXAMPLE 3: Rising conveyor belt

→ Maintenance switch must be accessible from the floor if parts of the machine are also accessible from the floor.

### 3.4 Indirect shutdown

According to EN 60204-1:2018 para. 5.4, indirect shutdown by devices without an isolating function (e.g. a contactor) is only permitted for inspection (measuring, testing, recording), adjustment or electrical work without risk of electric shock, i.e. not for work such as maintenance, repair, cleaning or troubleshooting.

Exceptionally – in deviation from EN 60204-1:2018 and EN ISO 14118:2018 – indirect shutdown may also be used in Switzerland in the following cases, subject to compliance with the requirements specified below:

- for higher power ratings (from 20 kW or from 10 mm<sup>2</sup> cross-section of conductors),

---

<sup>12</sup> Ordinance on Heavy Current (SR 734.2), Art. 3

- for special motor circuits (star-delta switch, electric power drive system with adjustable speed),
- for multiple drives that are combined in one functional unit,
- when different forms of energy such as electricity, pneumatics and hydraulics are to be shut down together.

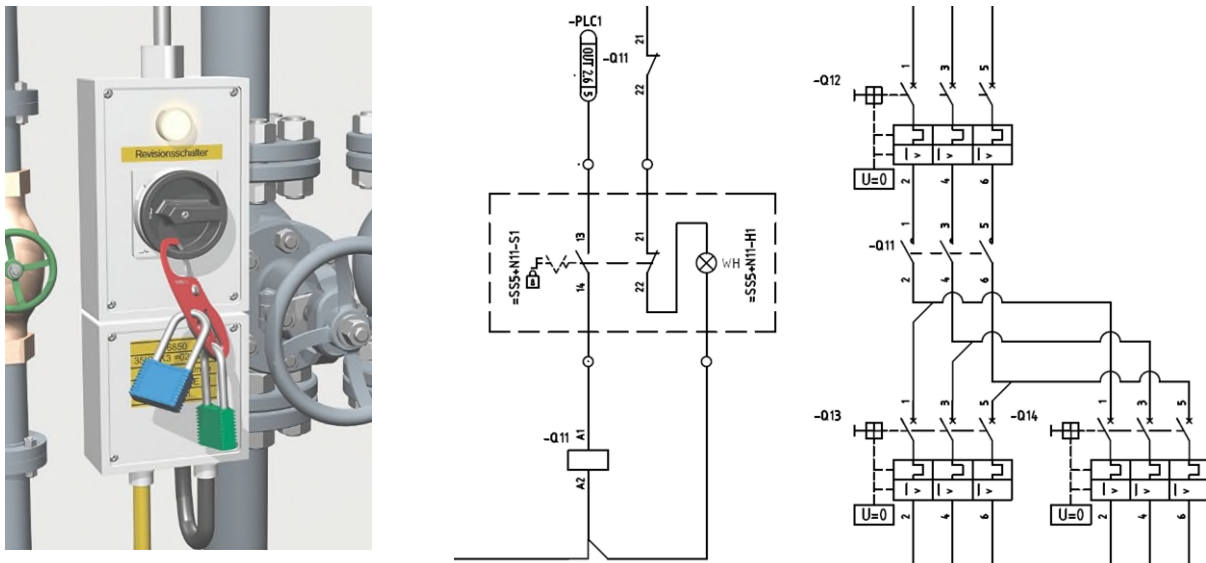

Figure 2: Maintenance switch, operating indirectly with signal lamp

The contactor lacks a reliable mechanical connection between the manual control (actuator) and the contact elements. The contactor, as a disconnecting element, is therefore not as safe as a positive opening switch and the following additional measures must be taken:

- The actual shutdown must be signalled (by a white signal light labelled “0” or “OFF”).
- This display must appear reliably: the contactor must have a forced control between the power and the signalling contact(s) (contactor with mirror contact according to product standard).

Reconnection must be prevented. As long as the maintenance switch is switched off, it is necessary to prevent the indirectly controlled switching elements from being actuated manually or by any other external influence (e.g. remote control). Manual activation can be prevented by one of the following measures:

- by using contactors without a manual actuation option, or
- by covering the relevant contactors with a warning sign (ISO 7010, W018). The covers providing this protection must only be removable with a tool, and the screw connections must remain on the cover after being loosened.



Figure 3: “Unexpected start-up” warning sign on the cover of contactors

Short circuits in the supply line to the maintenance switch must be prevented or detected, where mechanical or other hazards are present. This can be achieved by one of the following measures, for example:

- Mechanically protected routing of the switch supply line;
- Use of separately laid, shielded cables (shield earthed);
- Use of cables in which each core is separately shielded and earthed.

The function of the maintenance switch must have priority over all other functions. The maintenance switch must therefore operate as closely as possible and directly on the contactor coil. The control must not be performed or able to be influenced via other elements (PLC, bus systems, etc.), even if these are functionally safe (e.g. in accordance with EN ISO 13849-1 or EN 62061).

In controlled drives, a contactor must be used before or after the power drive controller for indirect shutdown. Shutdown with safety functions<sup>13</sup> (e.g. STO or SS1) is not equivalent to indirect shutdown by a contactor (no sufficient separation distance between opened contacts).

#### 4 Formation of functional units

A system or large machine must already be divided into appropriate functional units at the planning stage, and a maintenance switch must be assigned to each unit. The aim is to ensure that the operational and safety requirements for the machine are met. Functional units comprise those parts of a system that can only function together (see para. 7.5, Division of a system into functional units, Example 5).

If the system is not divided into functional units, there is a risk that during work such as maintenance, repair, cleaning or troubleshooting, the machine will not be switched off at the main switch, in order to at least partially maintain production.

Each functional unit must be able to be shut down with a separate maintenance switch (Ordinance on the Prevention of Accidents and Occupational Diseases, Art. 30).

In the case of extended functional units, the maintenance switches must be arranged in such a way that a maintenance switch is located in the immediate vicinity of each intervention point.

---

<sup>13</sup> EN 61800-5-2



## 5 Main switch as maintenance switch

The main switch (system switch) can be used as a maintenance switch if the following conditions are met:

- the system must constitute a single functional unit;
- the main switch must be located in the immediate vicinity of the system.

Where mechanics and electricians as well as operators and assistants use the main switch and/or the maintenance switch, it must be possible for these switches to be actuated without having to open an electrical control cabinet.

If the handle of the switch is mounted on the cabinet door, there is a risk that the switch will be switched back on after the door is opened by actuation of the coupling piece, even if the handle is locked with a personal padlock in the off position.

To prevent unintentional or unauthorised switching on, one of the following technical measures must be taken:

- a device shall be provided to prevent the door from opening for as long as the switch is locked in the off position,
- it must be mounted on a fixed part of the cabinet,
- a cut-out must be made in the cabinet door and a switch installed in a box in the cabinet so that the handle remains on the switch when the door is opened.

## 6 Instructions for users

The maintenance switch must be used by all persons who carry out interventions in a system.

Before starting work such as maintenance, repair, cleaning or troubleshooting, users must first shut down the system using the stopping device, then turn the maintenance switch to the “0” position and secure it against unauthorised restarting with the personal padlock.

A personal padlock is to be provided to the users concerned. They must be given appropriate training. Each person secures themselves with their own personal padlock and removes it after finishing the work.

Compliance with this regulation is to be monitored by the supervisors.

See also “Acht lebenswichtige Regeln zur Instandhaltung”, Publication number 84040.d (leaflet) und 88813.d (instructional aid).



### 7.2 Direct shutdown, Example 2

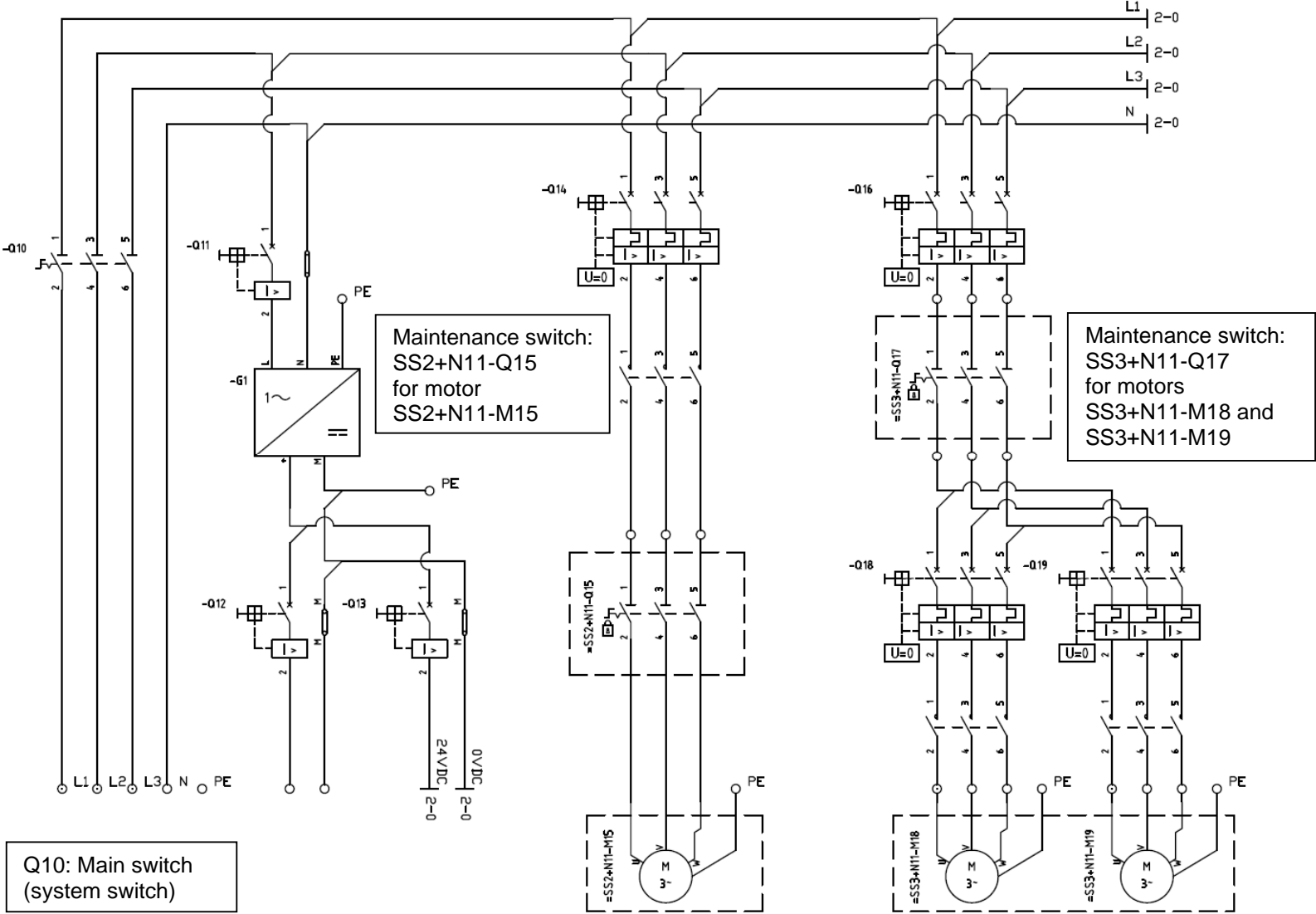

### 7.3 Indirect shutdown, Example 3

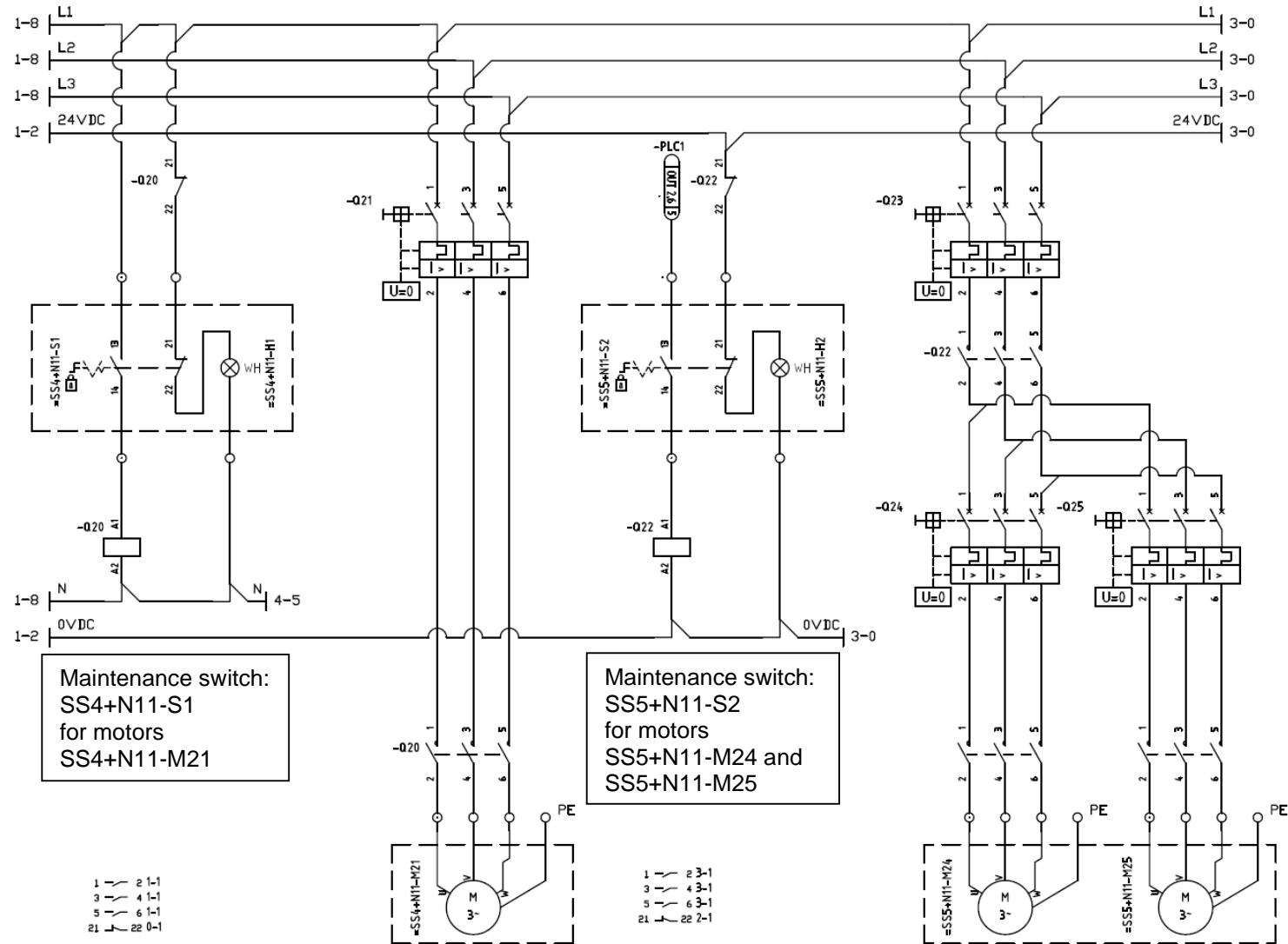

### 7.4 Indirect shutdown, Example 4

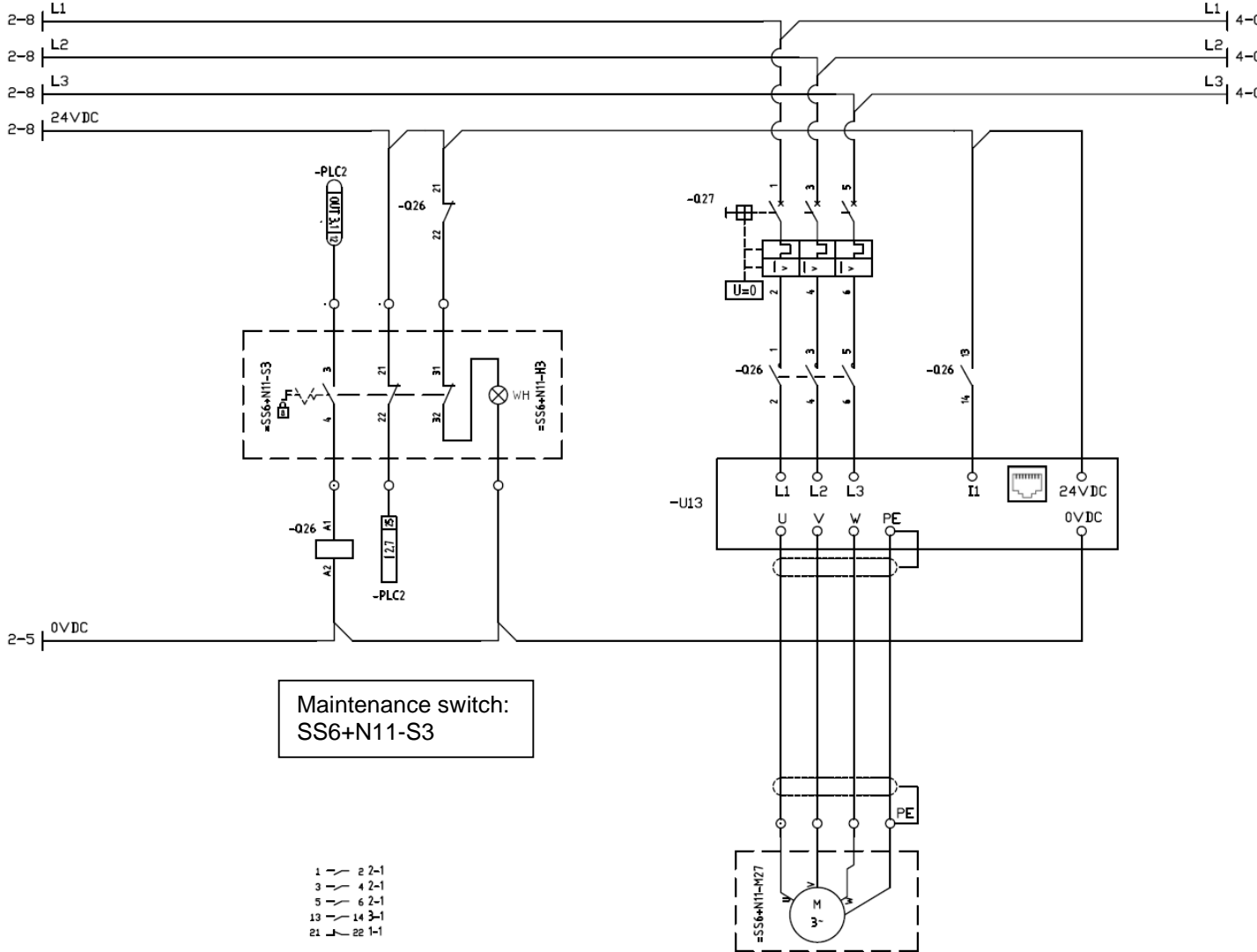

7.5 Division of a system into functional units, Example 5

