

suva

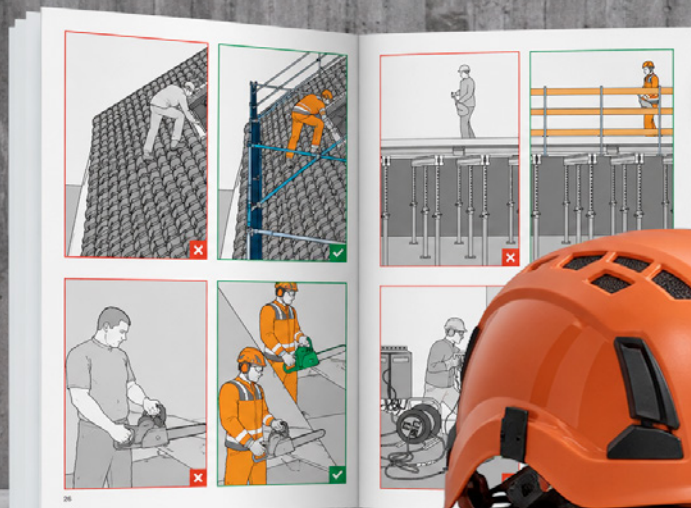

**Falsch – richtig:
Situations auf Baustellen**

**Faux – juste:
situations sur les chantiers**

**Sbagliato – giusto:
situazioni sui cantieri**

Suva

Postfach, 6002 Luzern

Auskünfte

Bereich Bau

Tel. 058 411 12 12

kundendienst@suva.ch

Bestellungen

www.suva.ch/11043.m

Titel

Falsch – richtig:

Situationen auf Baustellen

Gedruckt in der Schweiz

Abdruck – ausser für kommerzielle Nutzung – mit Quellenangabe gestattet.

Erstausgabe: 1987

Überarbeitete Ausgabe:

Juni 2026

Publikationsnummer

11043.m

Suva

Case postale, 6002 Lucerne

Renseignements

Secteur génie civil et bâtiment

Tél. 058 411 12 12

service.clientele@suva.ch

Commandes

www.suva.ch/11043.m

Titre

Faux – juste:

situations sur les chantiers

Imprimé en Suisse

Reproduction autorisée, sauf à des fins commerciales, avec mention de la source.

1^{re} édition: 1987

Edition revue et corrigée:

juin 2026

Référence

11043.m

Suva

Casella postale, 6002 Lucerna

Informazioni

Settore costruzioni

Tel. 058 411 12 12

servizio.clienti@suva.ch

Ordinazioni

www.suva.ch/11043.m

Titolo

Sbagliato – giusto:

situazioni sui cantieri

Stampato in Svizzera

Riproduzione autorizzata, salvo a fini commerciali, con citazione della fonte.

Prima edizione: 1987

Edizione rivista e aggiornata:

giugno 2026

Codice

11043.m



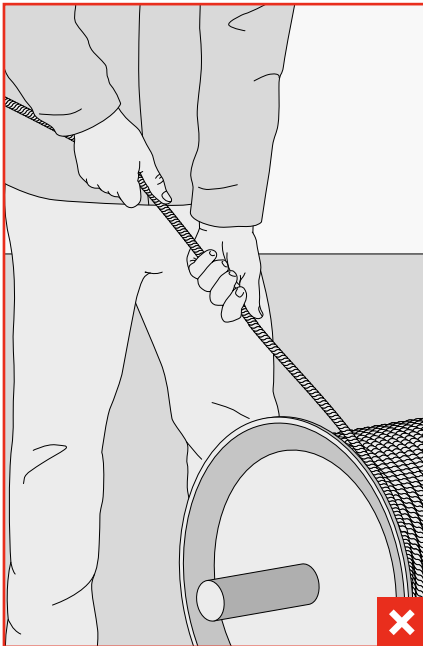
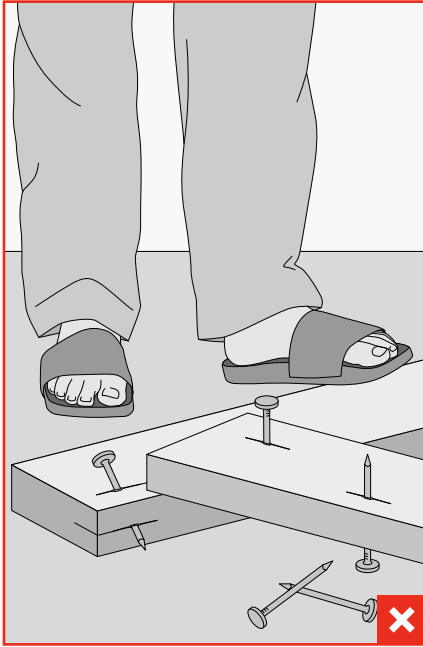

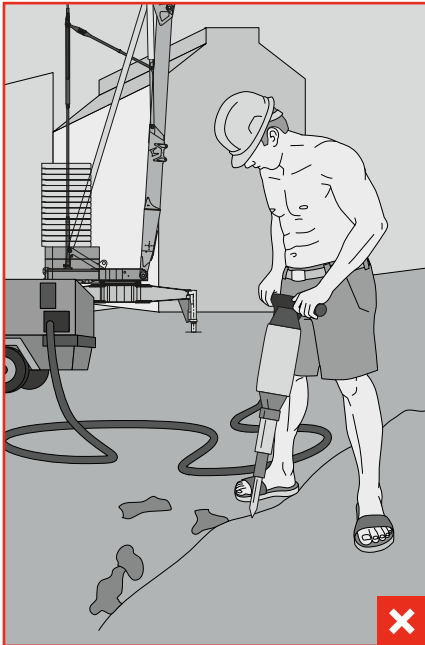
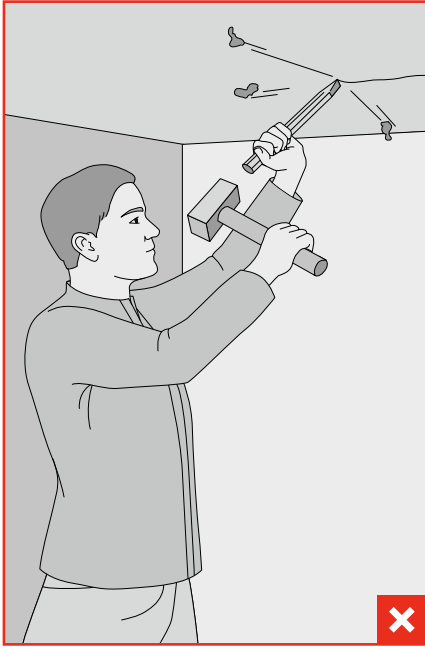

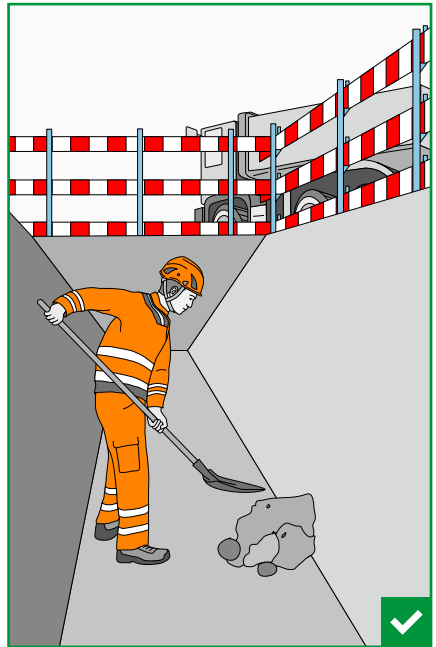

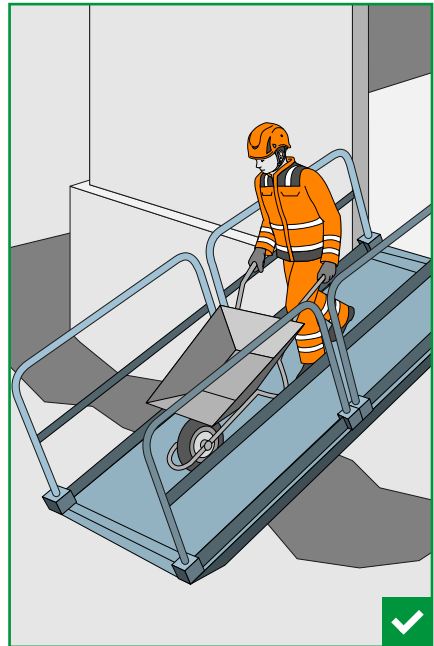
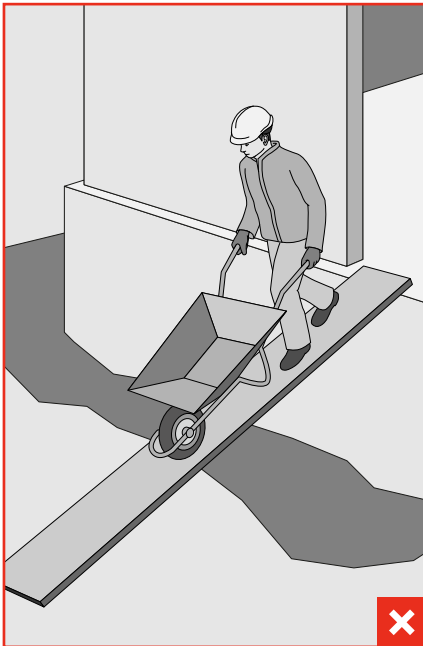
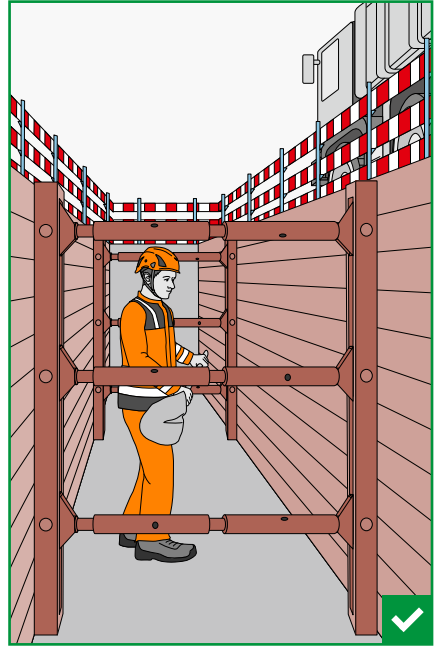
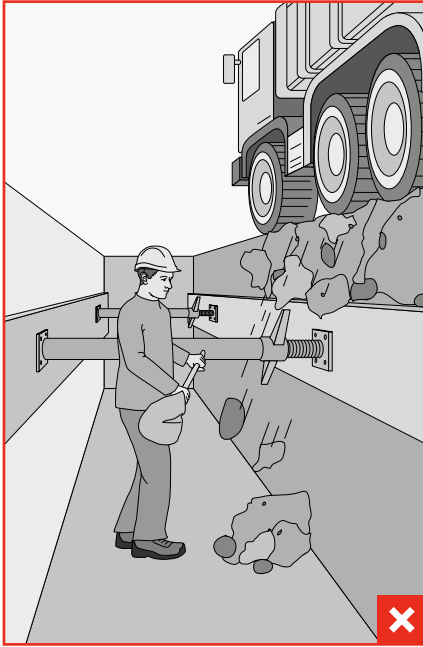

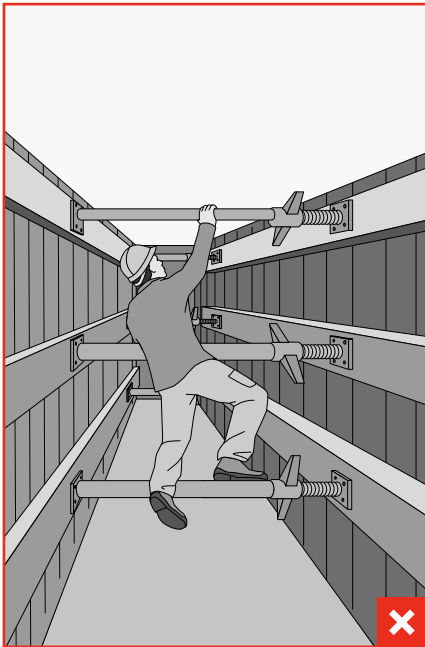

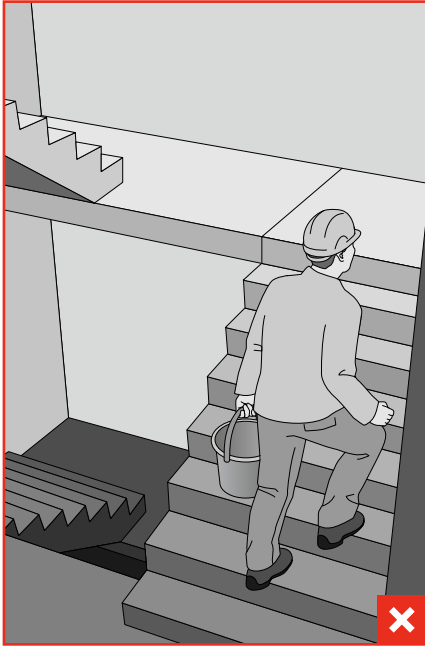

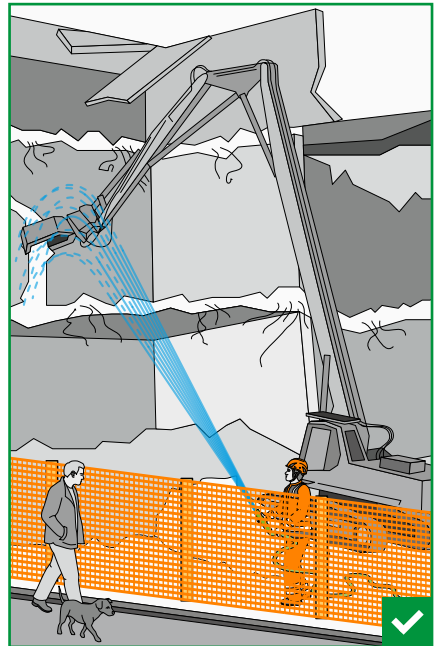
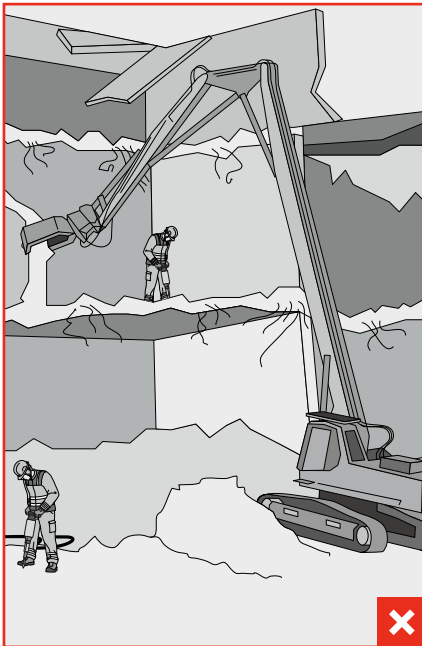
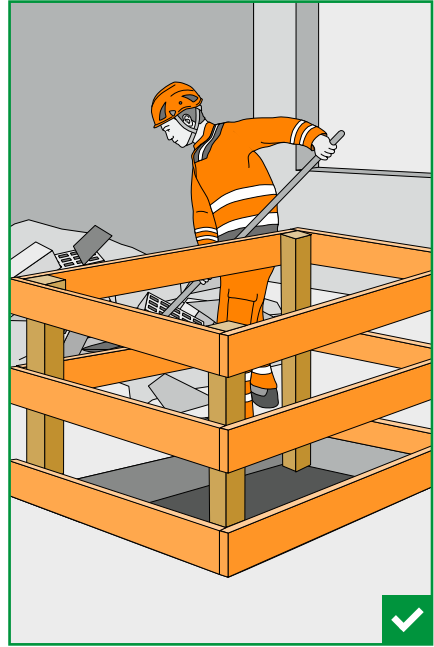

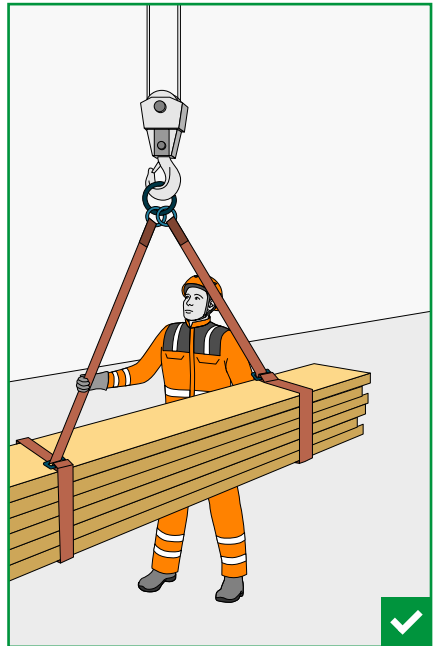
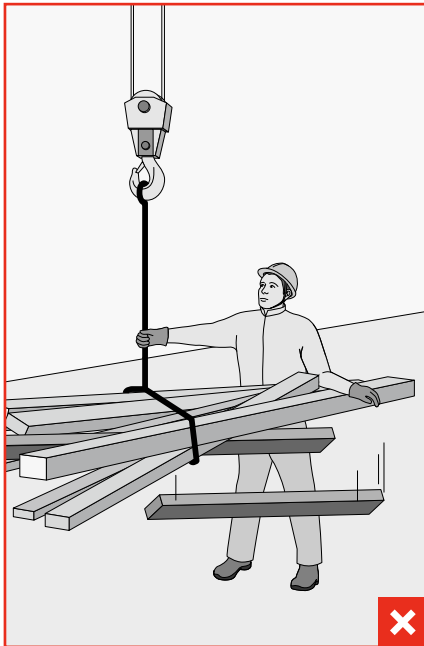
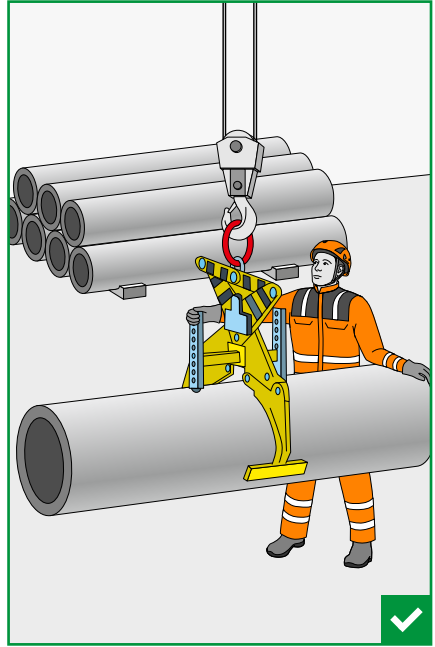
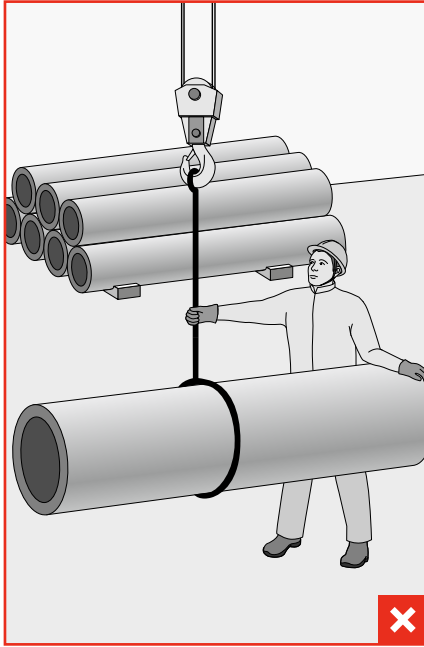

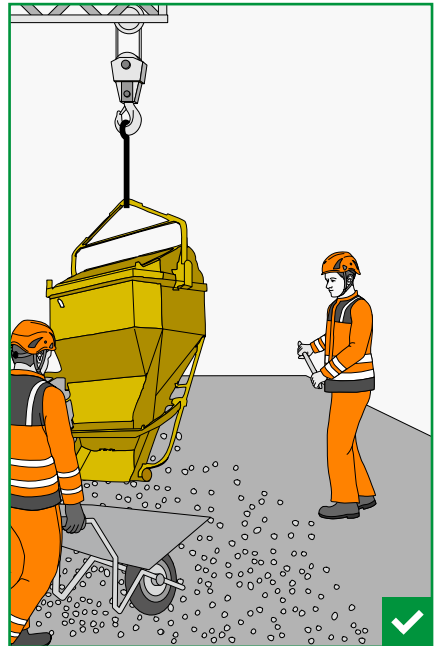
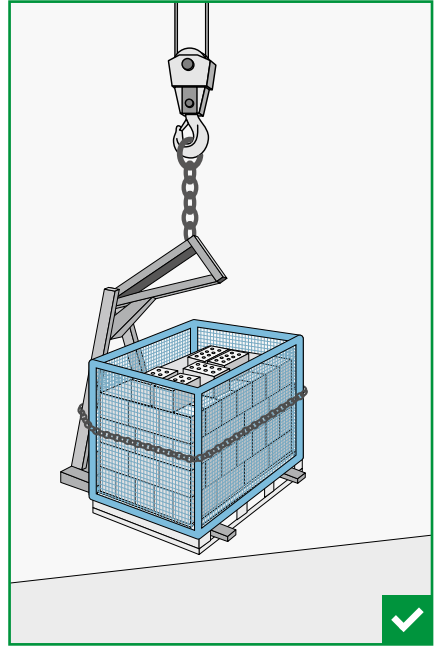
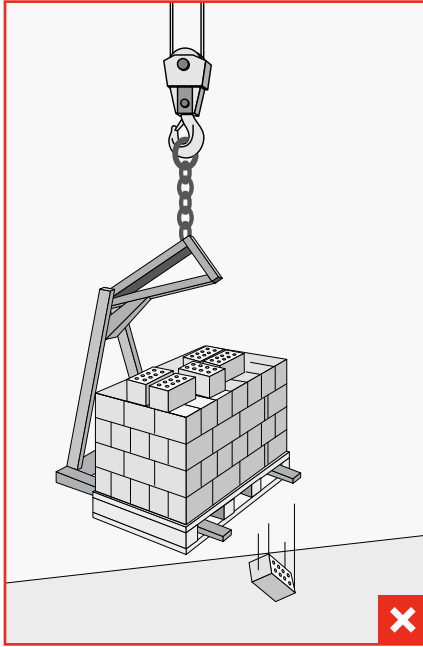

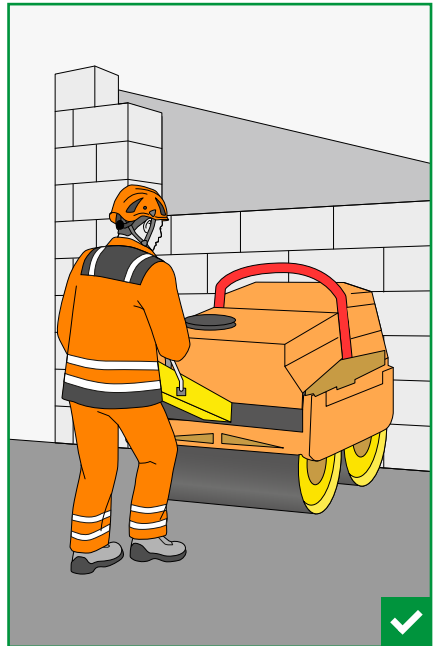
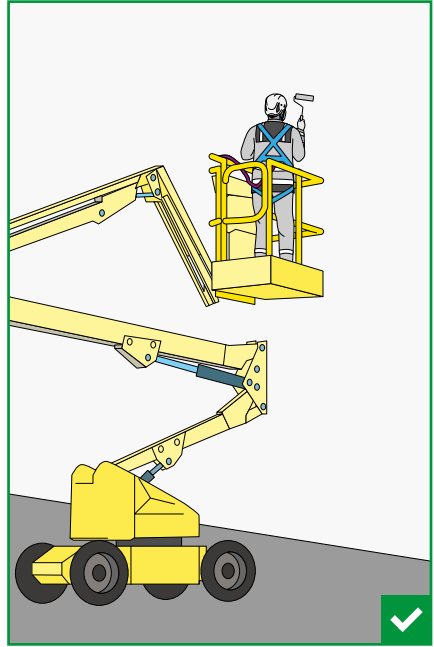
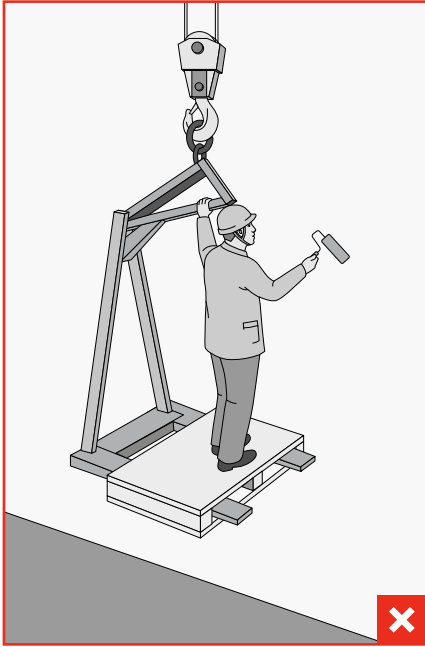

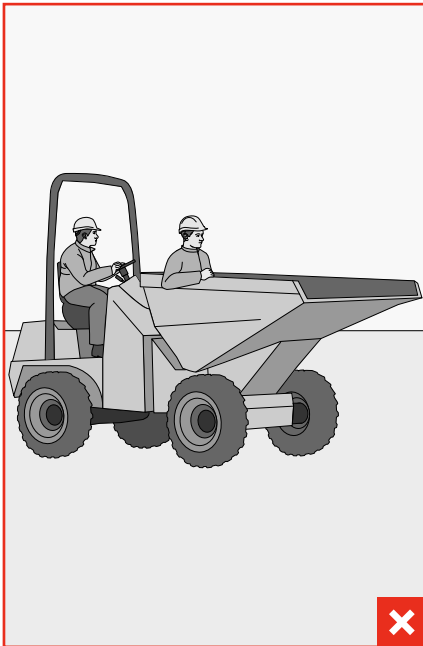
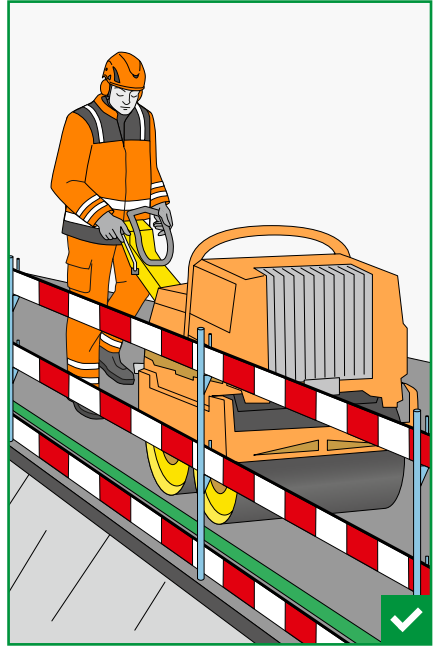

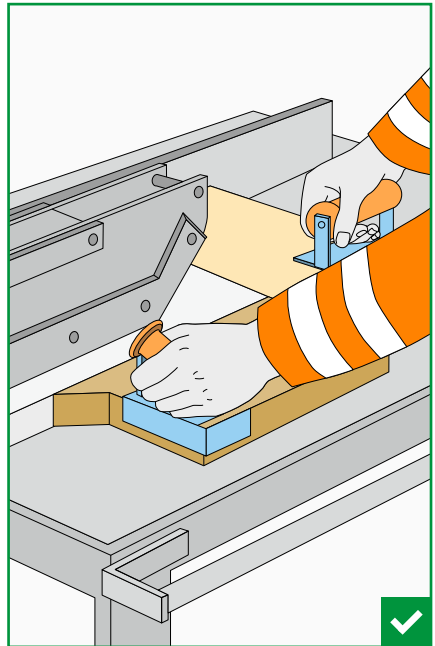
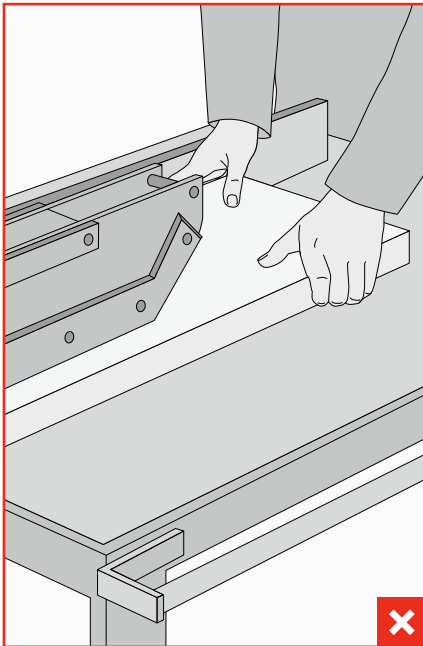
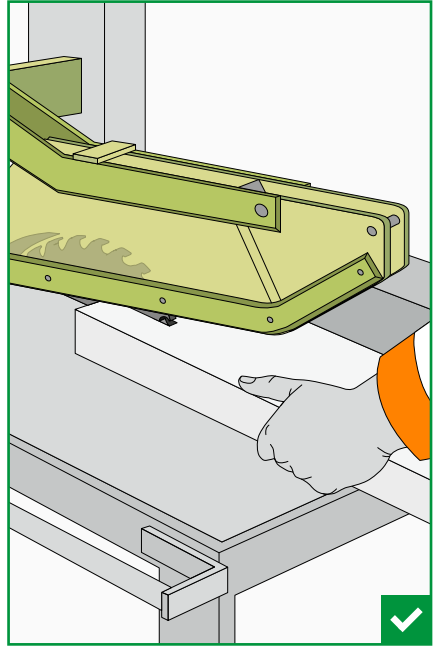
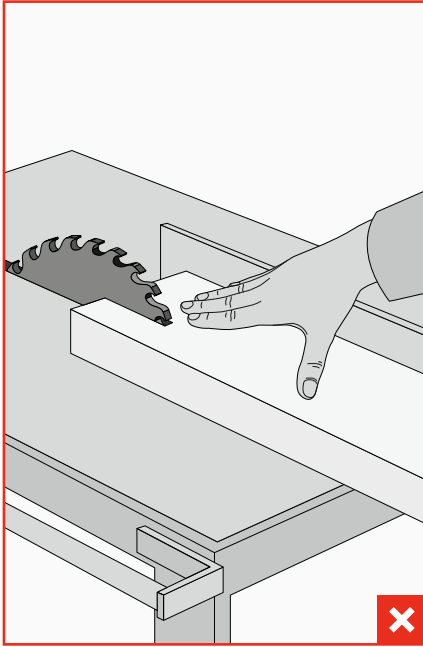

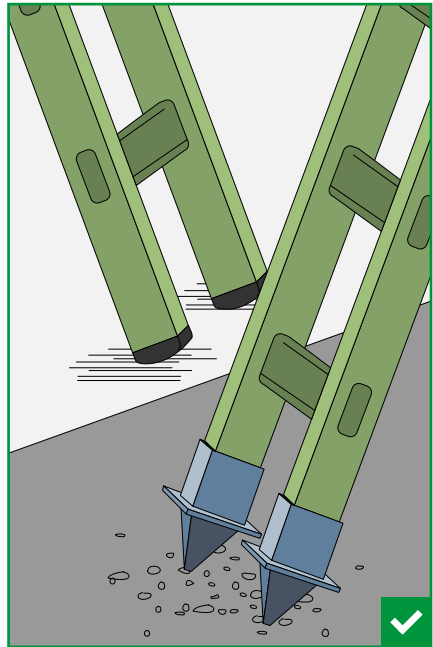
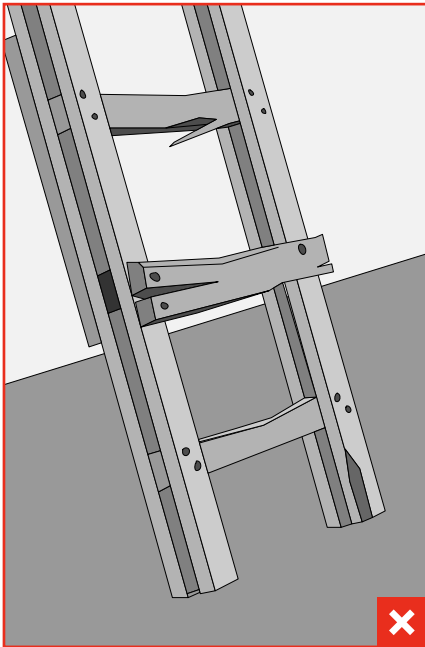

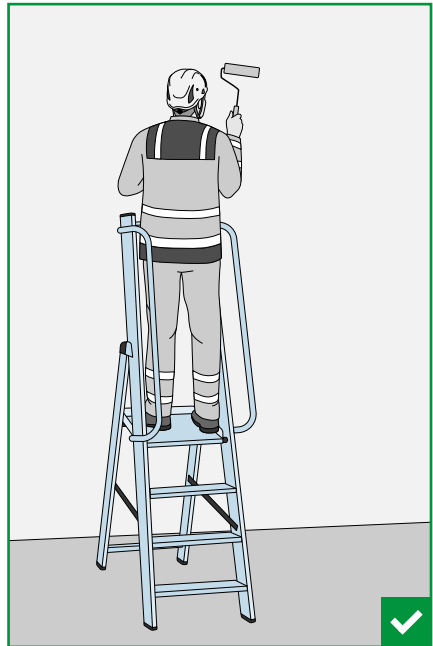

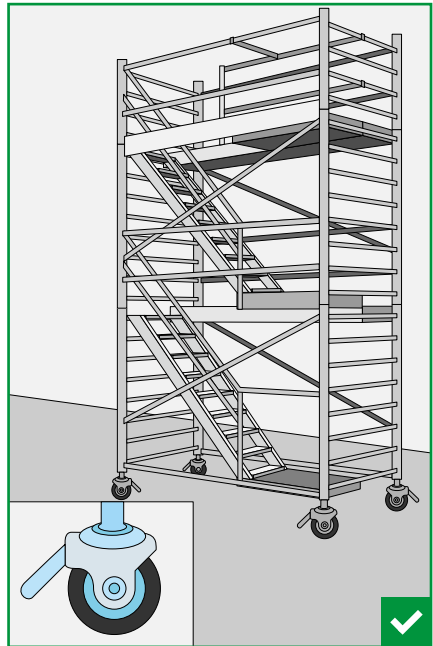
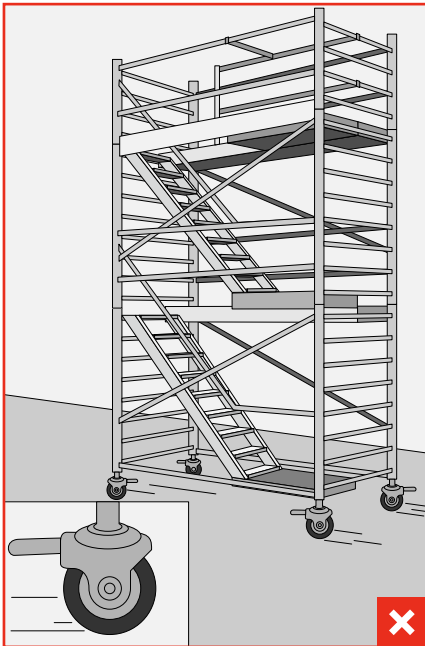

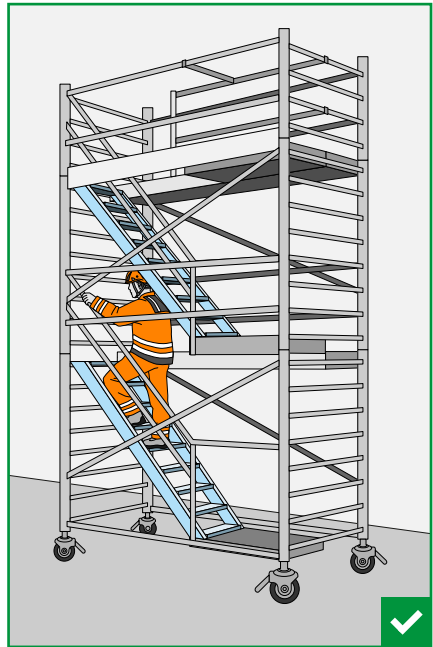
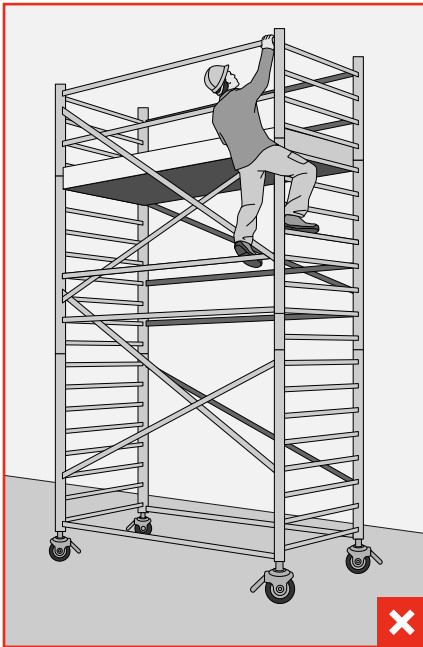
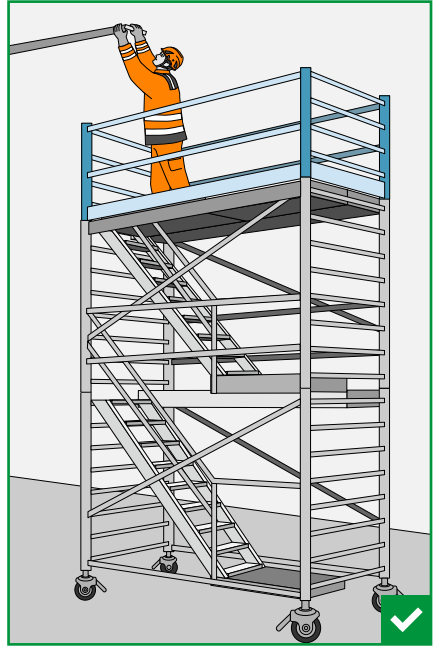
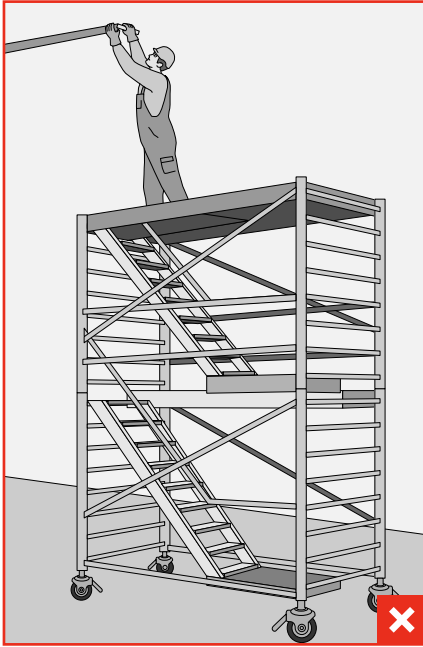

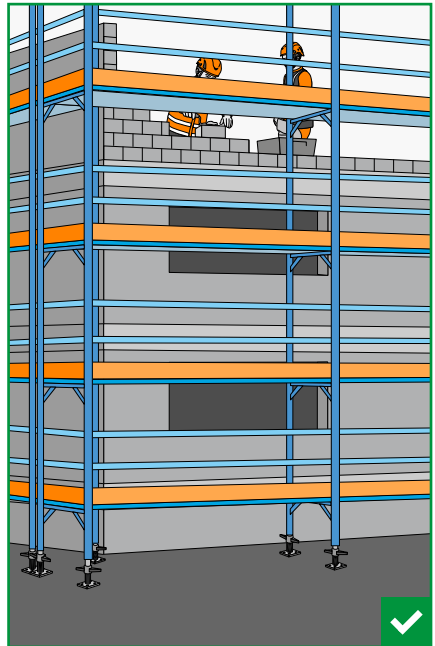
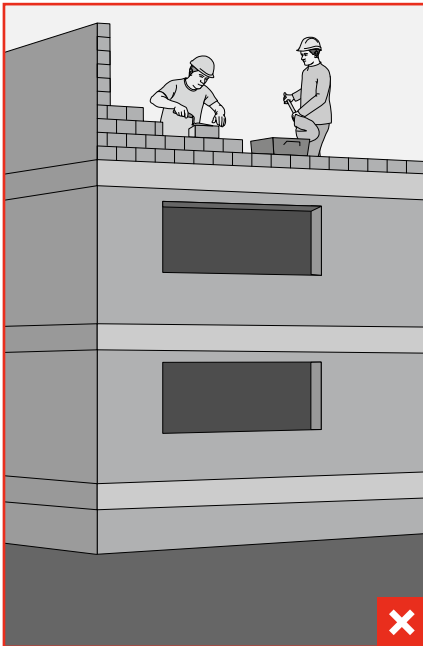
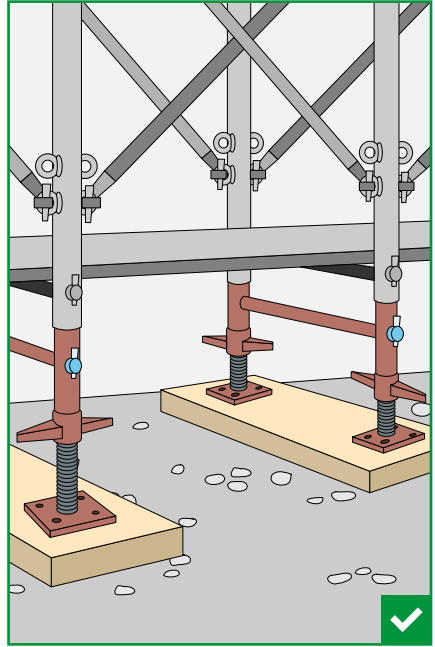
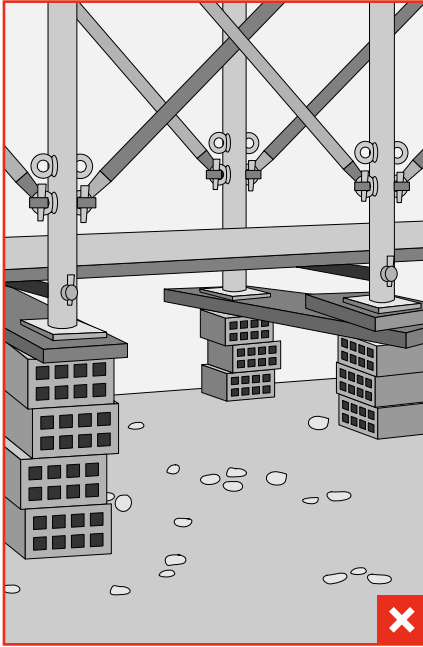

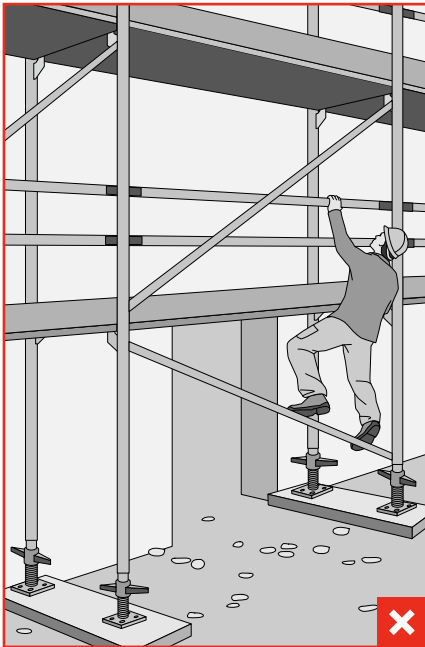
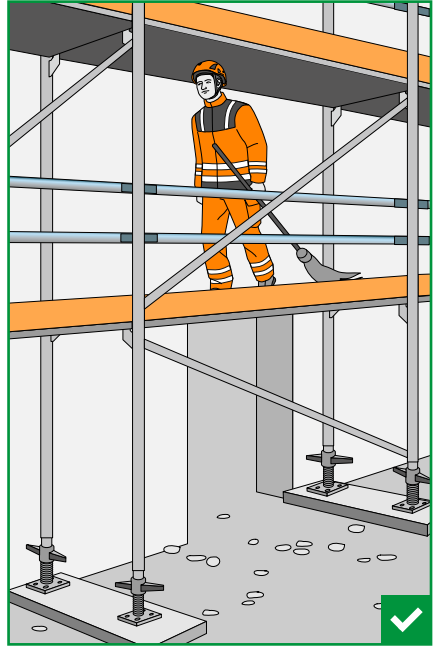
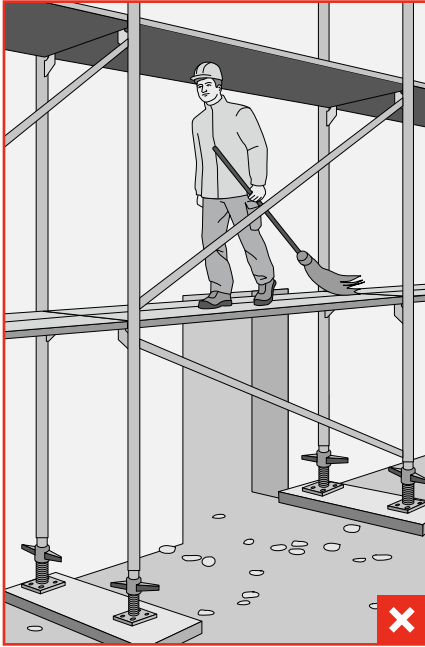

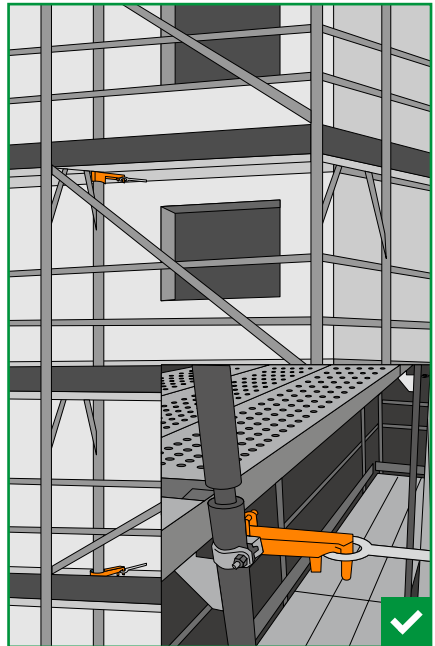
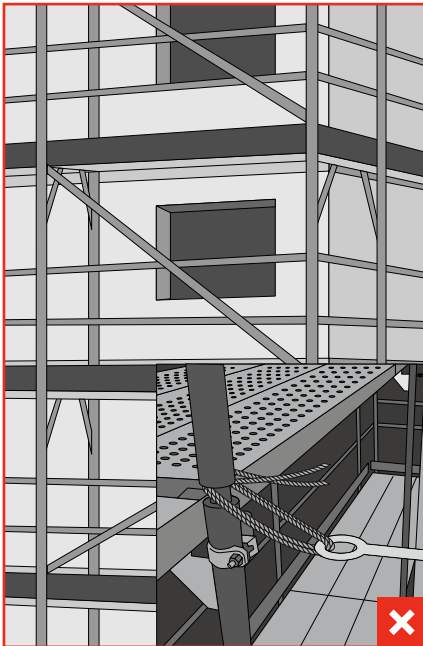

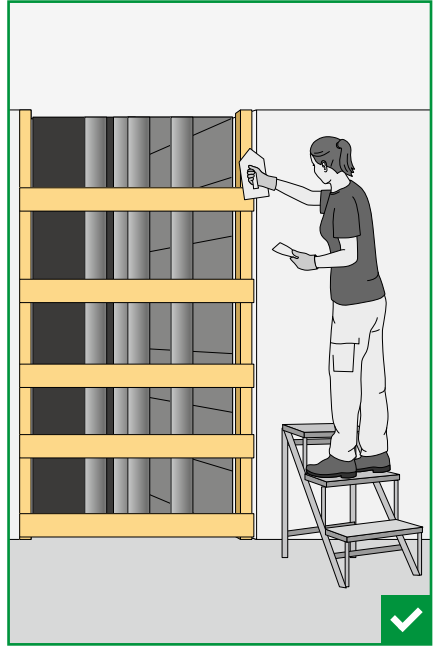
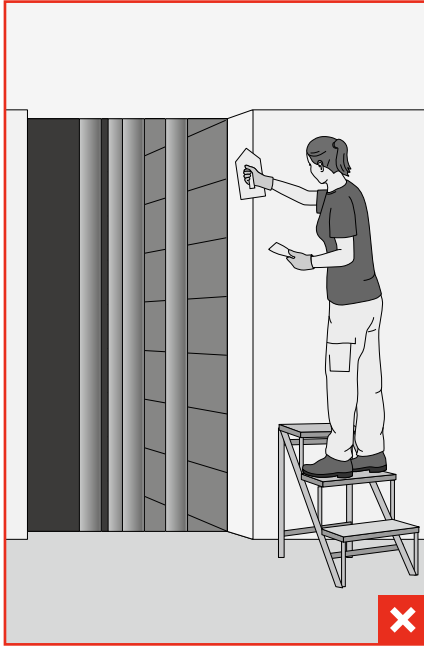

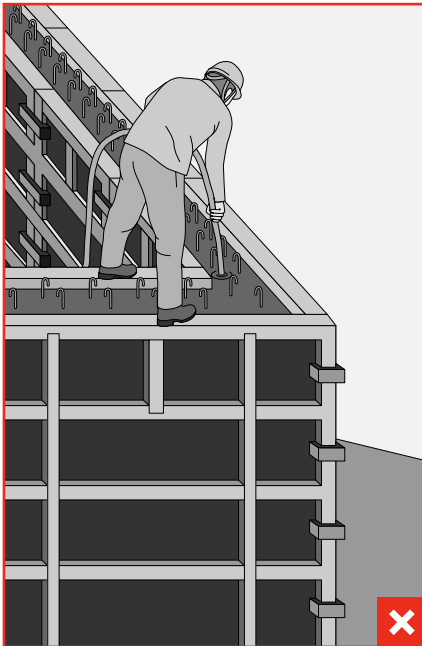
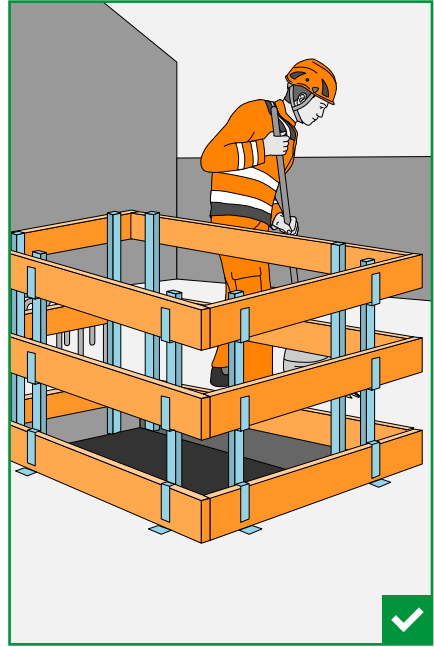
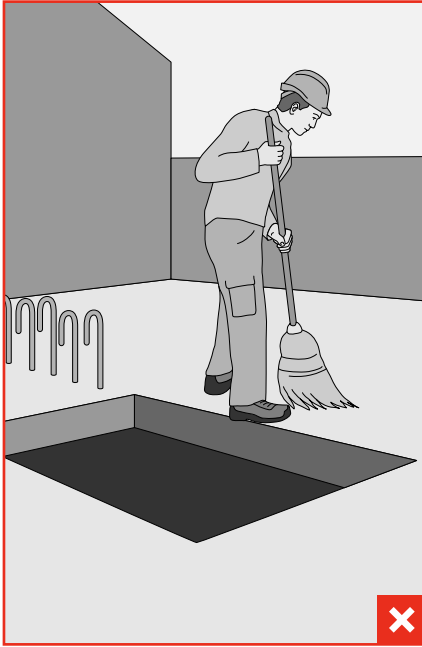

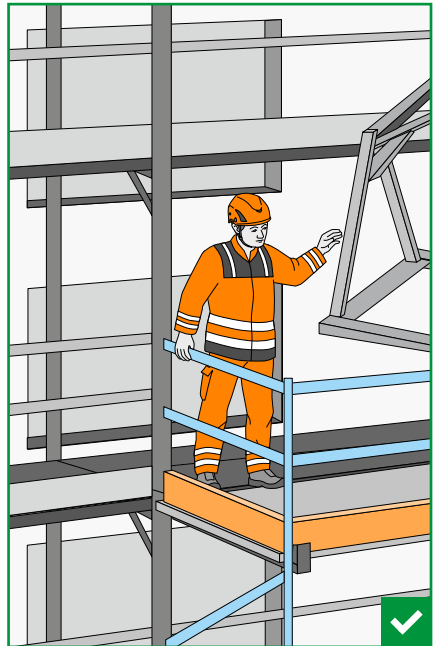
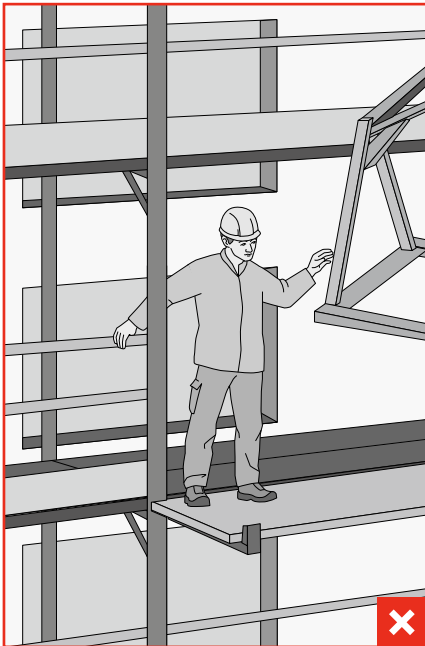
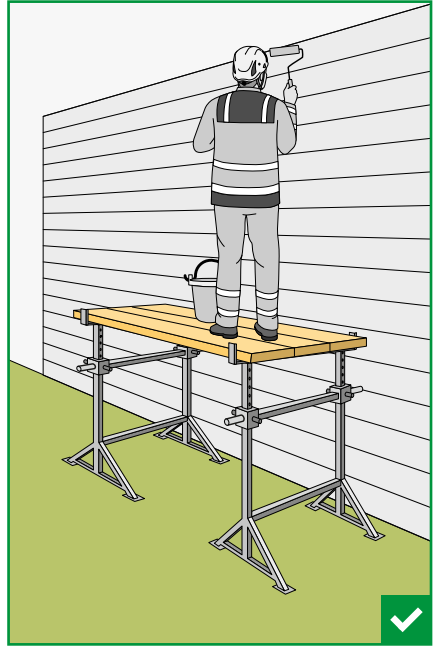
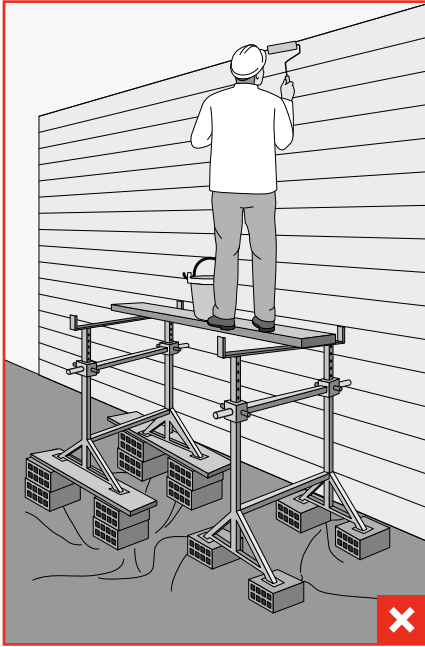

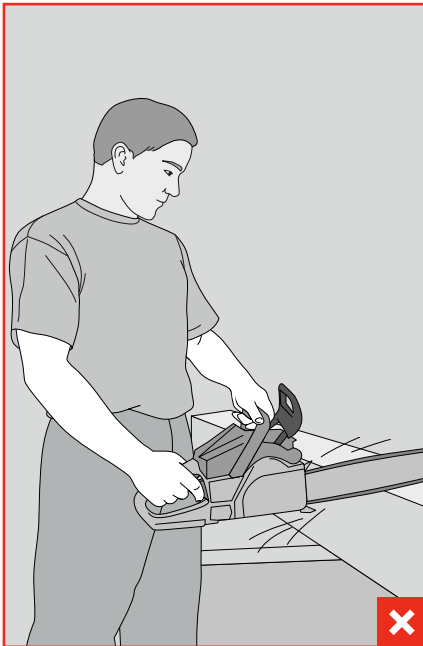
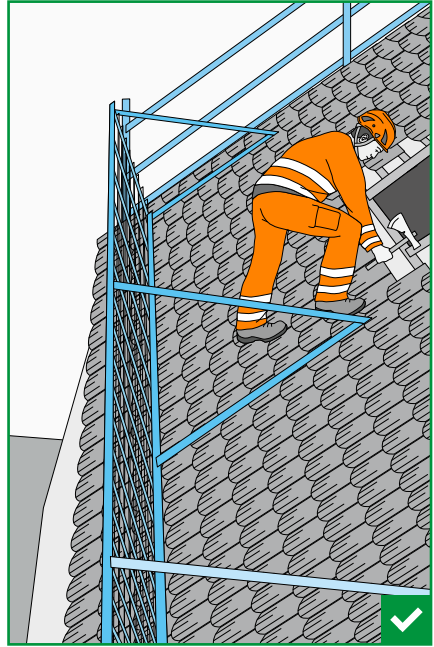

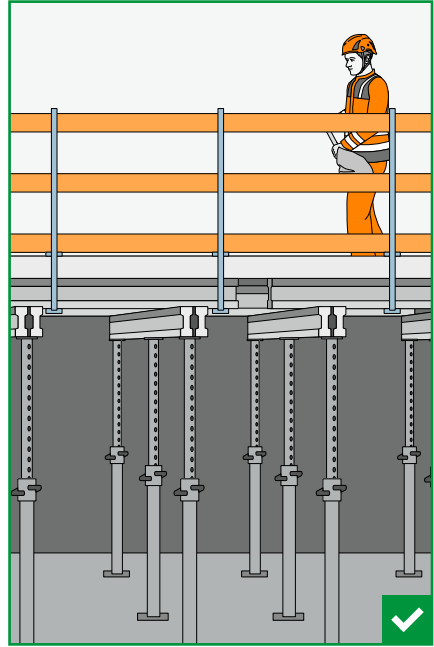
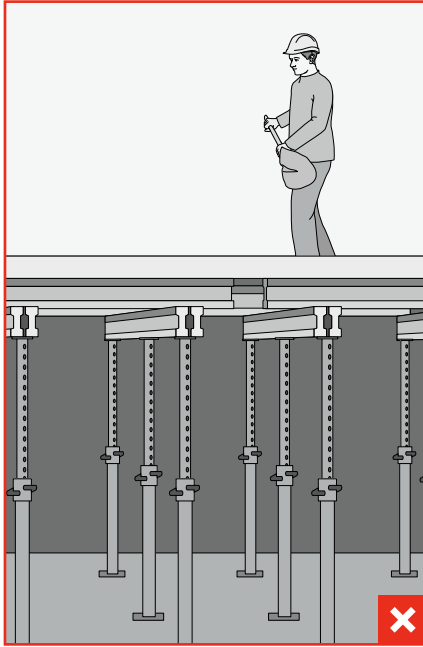

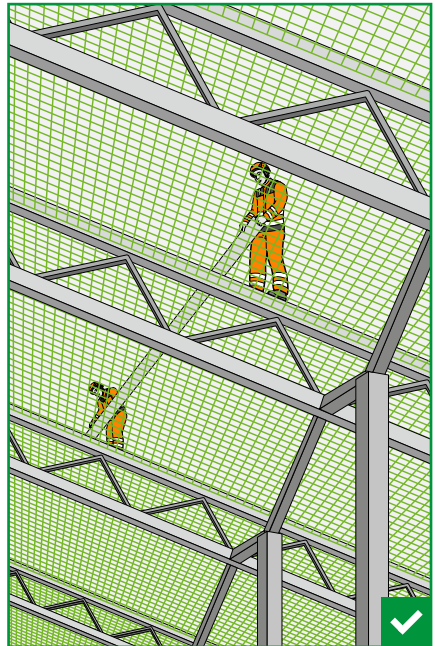
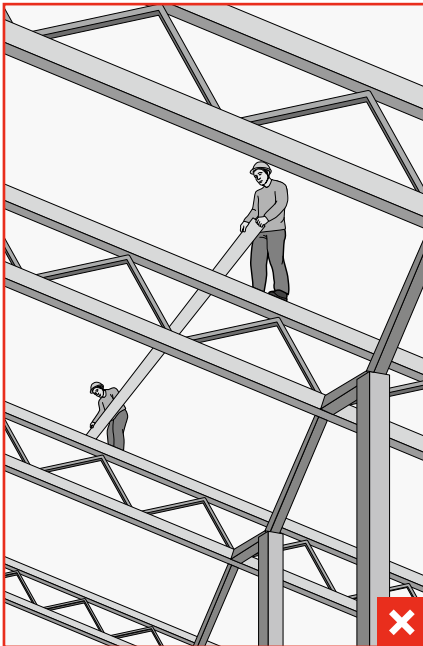
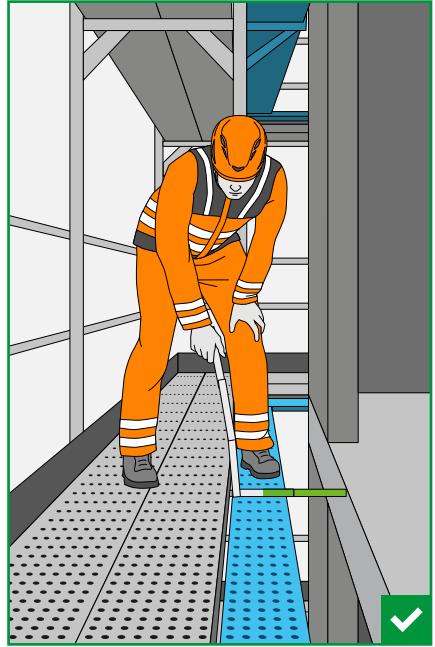

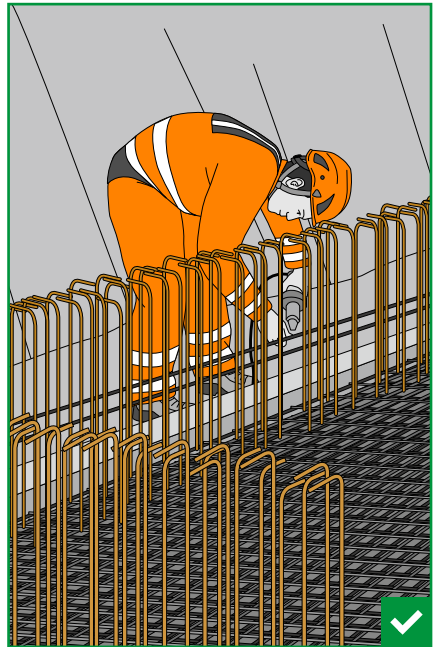
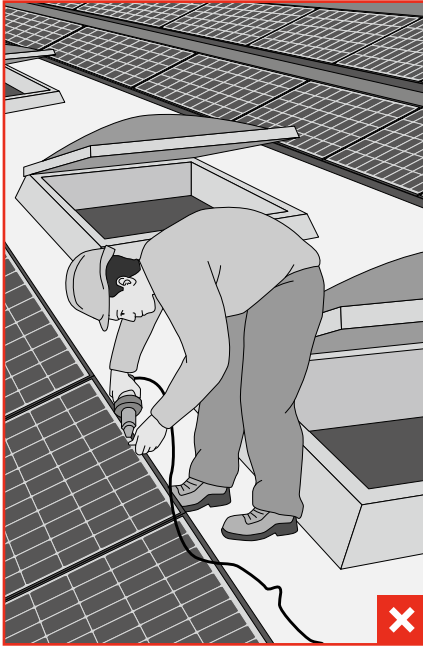

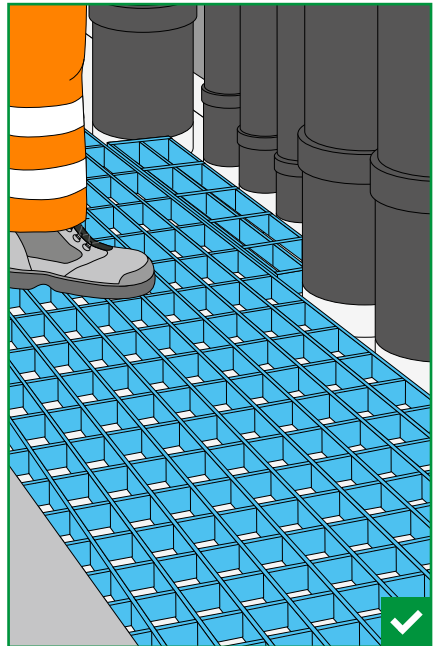
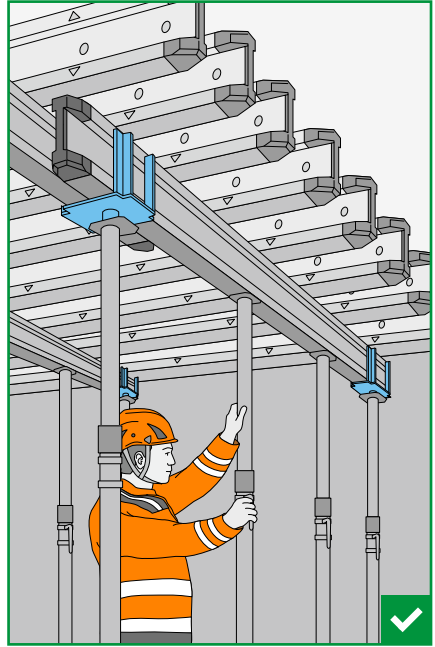



Das Modell Suva – Die vier Grundpfeiler

Le modèle Suva – Les quatre piliers

Il modello Suva – I quattro pilastri



Die Suva ist mehr als eine Versicherung. Wir vereinen Prävention, Rehabilitation und Versicherung unter einem Dach.

La Suva est bien plus qu'une assurance. Nous réunissons sous un même toit la prévention, l'assurance et la réadaptation.

La Suva è più che un'assicurazione. Coniughiamo prevenzione, riabilitazione e assicurazione all'interno di un'unica realtà.



Die Suva ist nicht gewinnorientiert. Überschüsse geben wir in Form von tieferen Prämien an unsere Versicherten weiter.

La Suva est une entreprise à but non lucratif. Nous reversons les excédents de recettes à nos assurés sous la forme de primes plus basses.

La Suva non persegue scopi di lucro. Assegniamo le eccedenze ai nostri assicurati sotto forma di riduzione dei premi.



Die Suva wird partnerschaftlich geführt. Bei uns entscheiden Arbeitgeberverbände und Gewerkschaften gemeinsam, auch über die Prämienhöhe.

La Suva est gérée sur une base partenariale. Chez nous, les associations patronales et syndicales prennent leurs décisions en commun, y compris sur le montant des primes.

La Suva è gestita in modo partenariale. Le associazioni dei datori di lavoro e i sindacati decidono insieme, anche sull'ammontare dei premi.



Die Suva erhält keine Steuergelder. Wir finanzieren uns durch Prämien und Kapitalerträge.

La Suva ne perçoit pas d'argent du contribuable. Notre financement repose sur les primes et les produits du capital.

La Suva non ricorre al denaro dei contribuenti. Ci finanziamo tramite i premi e i redditi da capitale.